

Check Valve Ball Poppet Type Direct Acting SAE-10 Cartridge – 420 bar RV10A-01

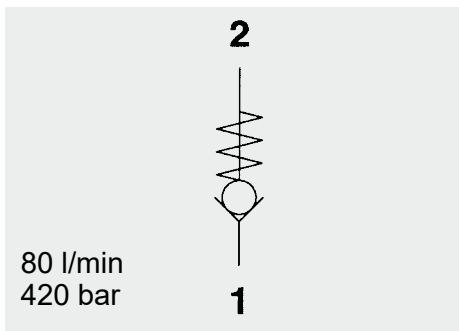

FUNCTION

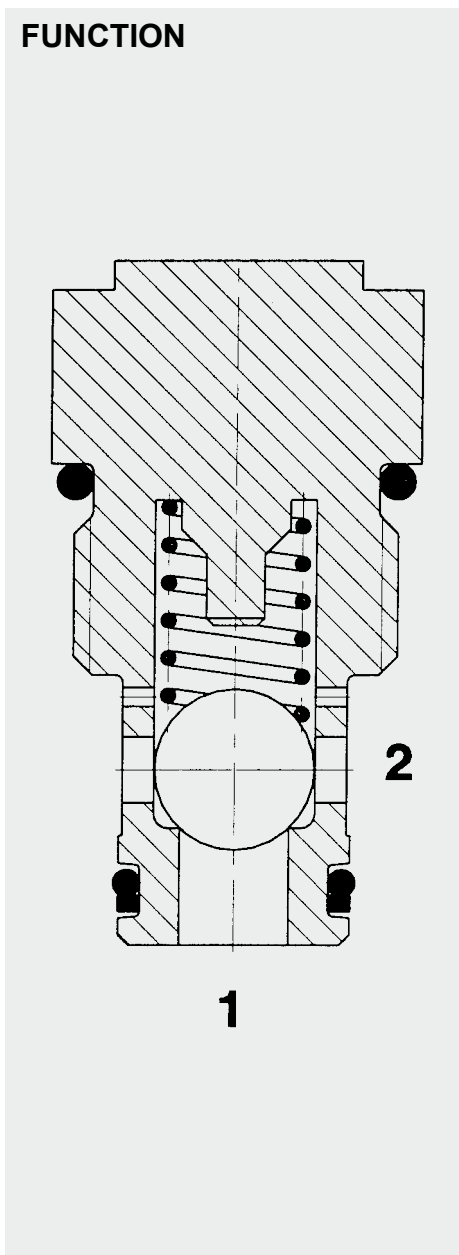

The check valve RV10A is a direct-acting, spring-loaded poppet valve. When there is no flow through the valve, the spring holds the ball in the closed position and therefore shuts off port 2 from port 1. The valve opens when the pressure at port 1 is higher than the pressure at port 2, including the pressure created by the spring force.

FEATURES

- External surfaces zinc-plated and corrosion-proof
- Hardened closing element
- Low leakage design
- Compact design

SPECIFICATIONS

Operating pressure:	max. 420 bar
Nominal flow:	max. 80 l/min
Internal leakage:	max. 0.1 cm ³ /min at 420 bar
Cracking pressure:	0.35 bar 1.00 bar 2.00 bar 5.00 bar
Media operating temperature range:	min. -30 °C to max. +100 °C
Ambient temperature range:	min. -30 °C to max. +100 °C
Operating fluid:	Hydraulic oil to DIN 51524 Part 1 and 2
Viscosity range:	min. 7.4 mm ² /s to max. 420 mm ² /s
Filtration:	Class 21/19/16 according to ISO 4406 or cleaner
MTTF _d :	150 years (see "Conditions and instructions for valves" in brochure 5.300)
Installation:	No orientation restrictions
Materials:	Valve body: free-cutting steel Ball poppet: hardened and ground steel Seals: NBR (standard) FKM (optional, media temperature range -20 °C to +120 °C)
Cavity:	FC10-2
Weight:	0.1 kg

DIMENSIONS

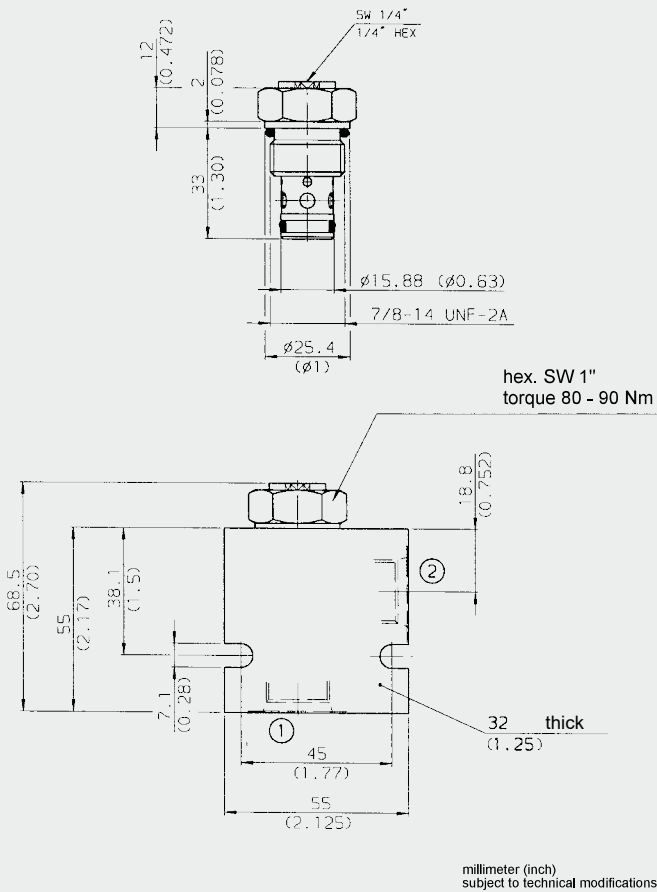

MODEL CODE

RV10A-01 - C - N - 05

Basic model

Check valve UNF

Body and ports*

C = cartridge only

SB4 = G1/2 ports, steel body

AB4 = G1/2 ports, aluminium body

Seals

N = NBR (standard)

V = FKM

Cracking pressure

05 = 0.35 bar (5 PSI)

15 = 1.00 bar (15 PSI)

30 = 2.00 bar (30 PSI)

70 = 5.00 bar (70 PSI)

Standard models

Model code	Part No.
RV10A-01-C-N-05	3014052
RV10A-01-C-N-15	3014103
RV10A-01-C-N-30	3014104
RV10A-01-C-N-70	3014105

*Standard in-line bodies

Code	Part No.	Material	Ports	Pressure
FH102-SB4	3037594	Steel, zinc-plated	G1/2	420 bar
FH102-AB4	3037777	Aluminium, anodized	G1/2	210 bar

Seal kits

Code	Material	Part No.
FH102-N Seal kit	NBR	3033872
FH102-V Seal kit	FKM	3051757

CAVITY

FC10-2

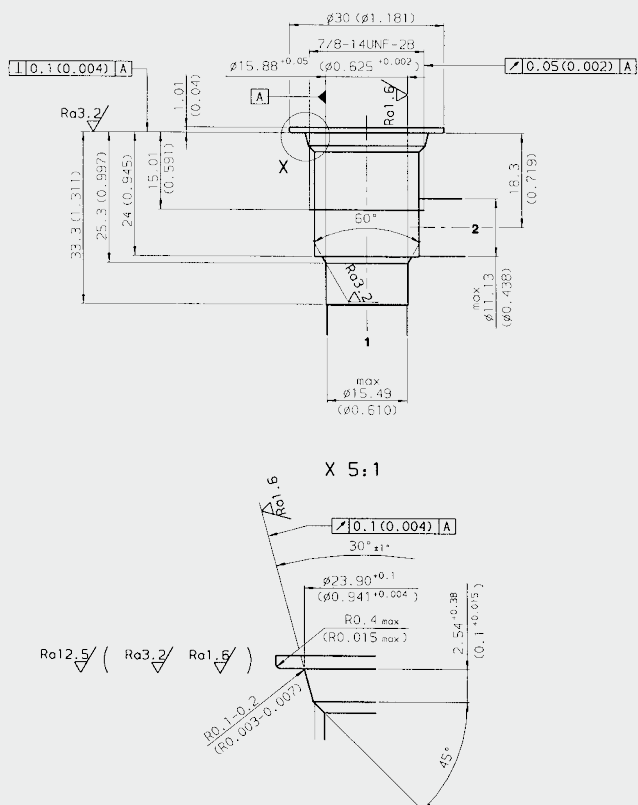

Form tools

Tool	Part No.
Countersink FC10-2	176379
Reamer FC10-2	165706

millimeter (inch)
subject to technical modifications

PERFORMANCE

Measured at $v = 34 \text{ mm}^2/\text{s}$, $T_{\text{oil}} = 46 \text{ }^\circ\text{C}$

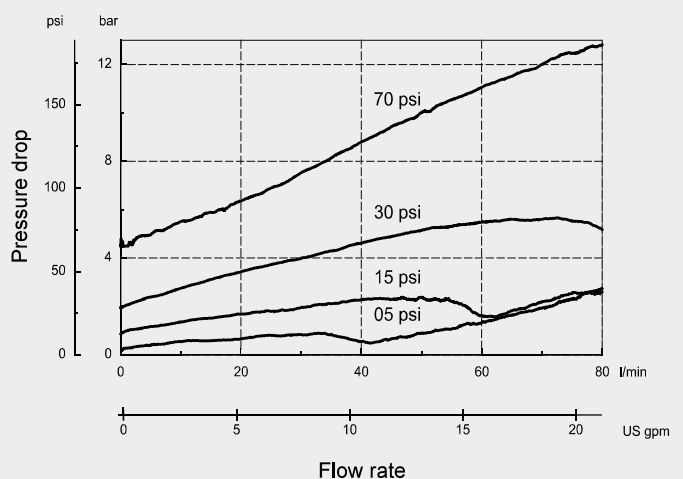

Note

The information in this brochure relates to the operating conditions and applications described. For applications or operating conditions not described, please contact the relevant technical department.
Subject to technical modifications.

HYDAC Fluidtechnik GmbH

Justus-von-Liebig-Str.

D-66280 Sulzbach/Saar

Tel: 0 68 97 /509-01

Fax: 0 68 97 /509-598

E-Mail: flutec@hydac.com